



# PRO290 STEAMER USER MANUAL

## Operating & Safety Instructions

Before using your Propress steamer, please read this manual thoroughly and retain it for future reference.

# CONTENTS

<b>1. Operating Safety</b>	<b>2</b>
<b>2. Unpacking Your Propress</b>	<b>4</b>
<b>3. Assembling Your Propress Steamer and Preparing for Use</b>	<b>5</b>
<b>4. Operating Instructions</b>	<b>8</b>
4.1 Filling Steamer with Water	8
4.2 Switching On	9
4.3 Using Your Steamer	10
4.4 Safety Filler Cap	10
4.5 Refilling Your Steamer	11
<b>5. Tips on Use</b>	<b>12</b>
5.1 Steaming Clothing	12
5.2 Full Garment	13
5.3 Wedding Dresses	13
5.4 Curtains & Soft Furnishings	14
5.5 Fabric Limitations	14
<b>6. Care and Maintenance</b>	<b>15</b>
6.1 Maintaining Your Steamer	15
6.2 Cleaning Your Steamer	15
6.3 Descaling Your Steamer	16
6.4 General Maintenance	16
<b>7. Storing your Propress When Not In Use</b>	<b>17</b>
<b>8. Propress Troubleshooting Matrix</b>	<b>18</b>
<b>9. Guarantee</b>	<b>21</b>

# 1. OPERATING SAFETY

Propress steamers are designed for vertical pressing of fabric and removal of creases, they should not be modified in any way to alter their operation.



**Propress steamers are electrical steam generating appliances, therefore components may get very hot and could cause burns.**

---

Maintain order in the working area, disorder increases the risk of an accident.

The appliance is not to be used by persons (including children) with reduced physical, sensory or mental capabilities, or lack of experience and knowledge unless they have been given supervised instruction.

Under no circumstances should the steamer be left unattended when in operation. When not in use disconnect the power supply.

Keep children away from the steamer. Children should be supervised to ensure they do not play with the appliance.

Regularly check power cable and plug when steamer is disconnected from the power supply.

Do not use the steamer if either power cable or plug are damaged; contact an approved service agent for repair.

Avoid use of extension cables. Incorrectly rated extension cables can be dangerous and a fire risk.

Regularly check hose for damage or distortion.

Never tilt or carry steamer when in use or when steamer contains hot water.

Do not unplug the steamer by pulling the electric cord, always switch off at the socket then firmly grip plug and pull out of socket.

Always disconnect from the power supply and wait for steamer to cool down before filling with water and mop up any water spillage before connecting steamer to power supply. Never detach hose or remove filler cap when machine is steaming or heating up.

Once a week the steamer should be cleaned. See section **6. Care and Maintenance**

Never steam yourself, others, or any clothing being worn.

Persons using the steamer must be authorised to do so and trained in safe working procedures. Where necessary, protective clothing should be worn.

To ensure appliance safety use only spare parts and accessories approved by the manufacturer. Service should only be carried out by the manufacturer or an approved service agent.

Ensure that filler cap with pressure release valve ball is always replaced on filler inlet and the ball is always free moving before switching steamer on. Never remove cap when steamer is in use.

Do not use steamer under a fire sprinkler system or smoke detector as the steam may trigger an alarm.

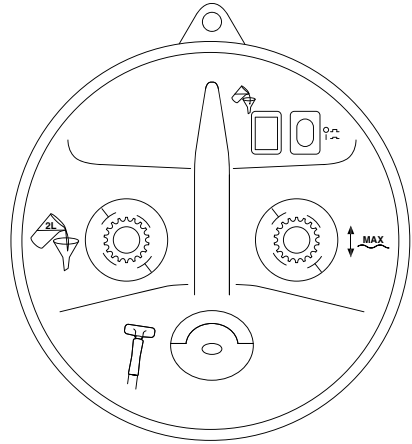

# 4. OPERATING INSTRUCTIONS

## 4.1 Filling Steamer with Water

1. Remove the Filler Cap from the steamer.

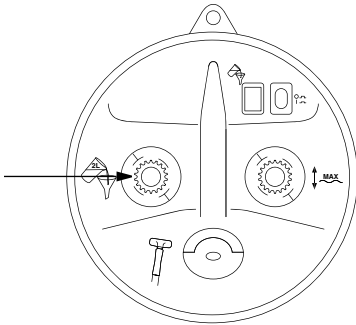

2. Measure 2L of hot or cold tap water and pour in using funnel supplied.

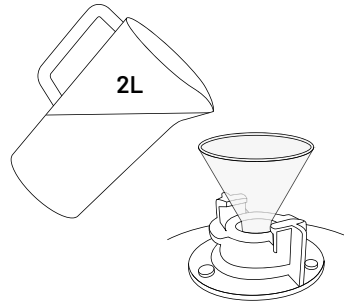

**Do not overfill. When the steamer is full the indicator float will appear in the sight glass.**



**Use only tap water. The addition of perfume or other agents will seriously damage your steamer and void the warranty. Refit filler cap. Ensure ball bearing within filler cap is always free moving before switching steamer on.**

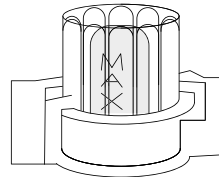

If condensation is restricting the view of the MAX symbol on the indicator float, remove cap by twisting anti-clockwise, wipe dry and refit.



**Never remove filler cap when in operation.**

If the float indicator is touching the top of the sight glass, the steamer has been overfilled. Empty excess water by removing the hose and pour out of steam outlet mopping up any spillage.

## 4.2 Switching On

1. Plug the steamer into a suitable power outlet and push down the green on/off switch that will illuminate to indicate the steamer is "on" and heating up.

**NOTE: The water in the steamer will take 10 to 15 minutes to produce steam, dependent upon the water temperature, ambient temperature and also the efficiency of your electrical supply.**

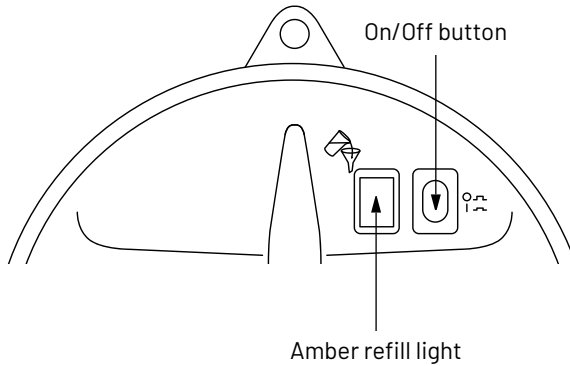

If the amber "empty/refill" indicator light illuminates and the buzzer sounds when the steamer is switched on, your steamer is empty of water. Turn off the power and refill according to instructions **Filling Steamer with Water**.

---

## 4. OPERATING INSTRUCTIONS (CONTINUED)

### 4.3 Using Your Steamer

**NOTE: Ensure the area you are steaming in is well ventilated.**

Once steam is emitting from the nozzle, allow the hose and nozzle to get hot for approximately 30 seconds before using the steamer. This reduces any condensation build-up.

Lift hose handle from the hook, shake/flick nozzle vigorously to remove any excess condensation before use and repeat periodically when steaming garments.

### 4.4 Safety Filler Cap

Your steamer is fitted with a safety filler cap. In some circumstances steam or water can be released from the filler cap. In the event that this occurs turn off immediately to ensure no damage is caused to the steamer or hose. **DO NOT REMOVE THE FILLER CAP. WAIT FOR STEAMER TO COOL DOWN.**

The potential causes of this are:

- The steamer has been overfilled
- The steamer needs rinsing out and descaling to remove build up of sediment or limescale
- The steamer hose is blocked, kinked or restricted



**Never leave hose assembly on the floor as this will cause a trip and burn hazard to the user and others and could damage the hose.**

---

When you have finished steaming, switch off the steamer using the green on/off switch and disconnect the power supply.



**Do not kink or restrict the hose, as this may cause an ejection of water and irreparable damage to hose.**

---

Always return the hose handle to the hook on the pole assembly when not in use.

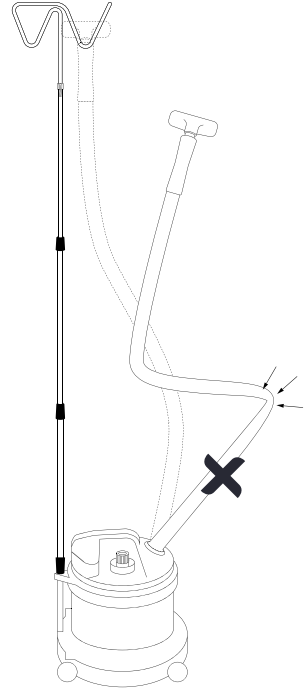

## 4.5 Refilling your Steamer

---



**Use extreme caution when removing the filler cap. Severe risk of burns from steam.**

---

When steamer runs out of water an alarm buzzer will sound and the amber 'refill' light will illuminate. Switch steamer off and disconnect from power supply. Wait for steamer to cool completely before removing the filler cap. Then follow instructions – **4.1 Filling Steamer with Water.**

Once refilled, the steamer will reset itself and can be switched back on for further steaming.

---



**Never use fabric freshening sprays near your steamer. If the body of your steamer comes into contact with this type of spray it can cause severe damage to your steamer and will void your warranty.**

---

# 5. TIPS ON USE

## 5.1 Steaming Clothing

Garments can either be steamed on a hanger, rail, mannequin or hung from the hook on the pole assembly.

**NOTE: Ensure that the pole hook is over the steamer when hanging garments on it. This maintains the stability of the machine.**

Run nozzle over the fabric while holding it taut with your free hand, taking care not to steam near your hand in the process.

Always keep the row of holes on the nozzle horizontal at all times.

If steaming at a low level regularly lift hose up so condensation can be allowed to run back into the steamer.

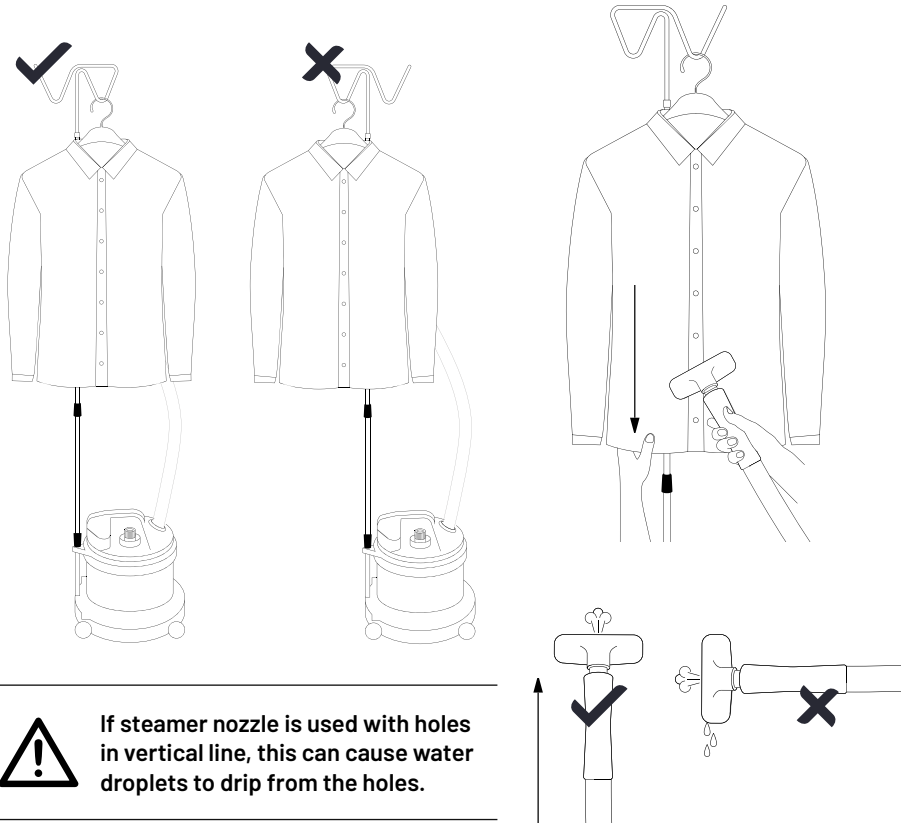

## 5.2 Full Garments

Full garments, such as dresses and skirts can be steamed from the inside by touching the nozzle on to material and steaming outwards. Caution is required as steam can build up inside the garment and get extremely hot. Steaming from the inside reduces the possibility of adding creases and opens up gathers; bringing dresses back to life.

## 5.3 Wedding Dresses

Wedding dresses should not be hung on the pole set as their weight can make the steamer unstable and topple over. They are best steamed hanging from a rail or, ideally, using a plastic chain attached to a hook in the ceiling. This allows the dress to be hung at different heights on the chain so the lower parts of the dress and the train can be steamed with ease. Steam the dress in sections, starting with the underskirt.

The back of the nozzle can be used as a low temperature iron to confirm creases and to shape collars.

If steaming at a low level, regularly lift hose up so condensation can be allowed to run back into the steamer.



**Never steam clothes whilst they are being worn by a person.**



**Use extreme caution when operating the appliance. Steam can burn.**

---



## 5. TIPS ON USE (CONTINUED)

### 5.4 Curtains & Soft Furnishings

Steam curtains from the face side.

If curtains are interlined, it may be necessary to steam lining as well.

Steam headings on curtains first, then work downwards.

If using optional Drapery Kit, it will be necessary to change to standard drapers hose when working at heights of less than 2m, otherwise a large amount of condensation will build up in the hose and cause reduced performance.

When steaming, periodically lift the hose so excess condensation can run back into the boiler.

Ideal for use on bed valances, chair covers, banquetting table cloths and removing pressure marks on carpets.

Mattresses and bedding can be steamed to freshen and remove creases.

### 5.5 Fabric Limitations

Not recommended for use:

- Moiré silk
- Seersucker
- Silk taffeta
- Artificial and natural furs
- Nap side of leather

If in doubt, test on a small inconspicuous area or steam from reverse side of fabric.

Extreme caution should be used with man-made pile fabrics to avoid shading – keep nozzle at least 10cm away from face or reverse, allowing steam to penetrate and use Propress velvet brush to maintain the pile.

Cotton and silk velvet can be steamed by lightly running the nozzle over the pile. In the event of a condensation spot on fabric, gently rub the back of the nozzle over the area. It should dry without leaving a water mark.

## 6. CARE AND MAINTENANCE

### 6.1 Maintaining your Steamer

To ensure a long and trouble free life of your steamer it is essential that it is flushed through with clean water every week to avoid the buildup of sediment and limescale. Descale regularly to ensure no unnecessary strain is put upon the heating element. Hard water causes scale to form on the heating element if not maintained properly; this will cause reduced performance, irreparable damage to the element and void your warranty.

### 6.2 Cleaning your Steamer

Disconnect from the power supply.

Remove steam hose and telescopic pole assembly.



**Steamer must be disconnected from the power supply.  
The water in the steamer must be allowed to cool to a temperature which will not cause injury before emptying.**

---

**NOTE: The steamer should be emptied through the steam outlet (not the filler inlet) into a ground level drain where possible to avoid raising the steamer up and emptying into a sink.**

Start by emptying any residue water from the steamer.

Remove the filler cap and fill steamer with 2L of clean water, replace the filler cap and agitate vigorously – this action will suspend some sediment in the water, immediately pour water out as directed above. Refill steamer with fresh water and empty again, repeat procedure until the water runs clear.

Periodically remove the sight glass on the indicator float chamber and clean the inside with a damp cloth to ensure you can see the float through the cap.

Clean the outside of the steamer with a damp cloth. Do not use any detergents or polish.

It is recommended the steamer be descaled using a non-aggressive descaler at least every 2 months. Descaling frequency is dependent upon usage and water hardness.

For details on suitable descalers, please contact Propress. We recommend the use of Propress Descaler which can be purchased by calling Propress on 020 8417 0660 or visiting [propress.co.uk](http://propress.co.uk).

## 6. CARE AND MAINTENANCE (CONTINUED)

### 6.3 Descaling your Steamer

Before descaling, carry out 6.2 Cleaning your Steamer to remove as much loose sediment as possible.

Always read Caution Instructions on descaling product and carefully follow directions.

Dissolve/dilute descaler in warm water, or as directed by the manufacturer, ensuring the correct water volume to descaler ratio is followed. Pour the diluted descaler solution into the steamer.

Replace filler cap and switch on the steamer.

As soon as water starts to boil, switch off, disconnect power and leave for a minimum of 3 hours. For best results leave to descale overnight.



**When descaler is left in the steamer, clearly label your steamer so no one attempts to use it.**

---

Before flushing descaler from the steamer, agitate vigorously then empty water out of steam outlet. Refill with clean water, agitate and flush out again. Repeat this procedure until the water drained is completely clear.

Failure to maintain your steamer will void its warranty.

**NOTE: the water in the steam generator must be allowed to cool to a temperature which will not cause injury before emptying.**

### 6.4 General Maintenance

In addition to mandatory electrical tests, regularly check the condition of the steamer's plug, cable and cable restraint for damage. If any damage is present DO NOT USE THE STEAMER and contact an approved service agent for repair. Ensure all warning labels are legible.

## 7. STORING YOUR PROGRESS WHEN NOT IN USE

The steamer should be emptied of water and cleaned. The electrical cable should be coiled and steamer stored in a dry location.

If the steamer is not to be used for an extended period of time it is recommended that the steamer is descaled before storage.

## 8. PROGRESS TROUBLESHOOTING MATRIX



Your Propress steamer operates at high temperatures and produces steam which can burn – use extreme caution. Troubleshooting should only be carried out by a competent person. Always allow steamer to cool down before commencing trouble shooting.

---

### NO LIGHTS COME ON AND STEAMER DOES NOT HEAT UP

<i>Probable Cause</i>	<i>Solution</i>
Steamer is not switched on, fuse in plug has failed or power outlet is not working/switched off.	Check steamer is switched on, plug into another power outlet, if steamer still not working try changing fuse in plug.

If steamer is still not working call your dealer to arrange service.

### DIRTY WATER COMING OUT OF FILLER CAP

<i>Probable Cause</i>	<i>Solution</i>
Steamer needs cleaning out or descaling.	Remove hose and poles from steamer and flush boiler as directed in 6.2 Cleaning your Steamer. If steamer has not been descaled recently, descale as directed in 6.3 Descaling your Steamer.

Failure to regularly clean the boiler and descale regularly will result in damage to the element.

### **WATER AND STEAM COMING FROM FILLER CAP**

<i>Probable Cause</i>	<i>Solution</i>
The steamer has been overfilled or the hose is kinked or damaged. Steamer nozzle being used at low level causing condensation to form in the hose.	Check water level in the steamer, if float is touching top of sight glass the steamer is overfilled. Remove poles and hose and empty excess water through hose hole. If not overfilled check hose for kinks and damage. Restrictions in the hose will cause safety valve in filler cap to operate and steam/water to escape from filler cap. If working at low levels lift the hose so condensation can run back into the steamer.

Hoses need replacing periodically and can be ordered from your local dealer.

### **BUZZING WHEN STEAMER IS NOT EMPTY**

<i>Probable Cause</i>	<i>Solution</i>
Thermal sensor is damaged or element heavily scaled.	Remove hose and poles from steamer and flush boiler as directed in 6.2 Cleaning your Steamer. After flushing boiler descale as directed in 6.3 Descaling your Steamer. If this does not correct problem call your dealer to arrange service.

We recommend the use of Propress Descaler which is available from your local dealer.

### **BURNING SMELL WHEN WATER LEVEL RUNS LOW**

<i>Probable Cause</i>	<i>Solution</i>
Element is scaled and surrounded by sediment.	Remove hose and poles from steamer and flush boiler as directed in 6.2 Cleaning your Steamer. After flushing boiler descale as directed in 6.3 Descaling your Steamer.

Keeping your steamer clean will extend the life of the element.

## 8. PROGRESS TROUBLESHOOTING MATRIX

### **NOZZLE HANDLE VERY HOT WHEN IN USE**

<i>Probable Cause</i>	<i>Solution</i>
Loose securing screw in handle.	Using appropriate screwdriver, check that screw in handle is tight.

If screw continually turns you will need to order a new hose set.

### **EXCESS WATER FROM STEAM NOZZLE**

<i>Probable Cause</i>	<i>Solution</i>
Nozzle has not been allowed to heat up fully before use, or nozzle is being used with holes lined up in vertical orientation. Screw in handle loose.	Always allow nozzle to heat up before touching fabric see 4.3 Using your Steamer and also see 5. Tips on Use. Check that screw in hose handle is tight.

Refer to full user manual for further details.



**FilmGEAR**rental  
+45 7022 0302  
filmgear@filmgear.dk